

Filmax

MODEL FP1105P PORTABLE FILTRATION SYSTEM

WATER & PARTICULATE FILTRATION SYSTEM FOR INDUSTRIAL MAINTENANCE



APPLICATIONS

Hydraulic Oil • Quench Oil • Synthetic Oil
Water Glycols • Turbine Oil • Gear Oil
Cutting Oil • Lube Oil

SPECIFICATIONS

- 1/2 HP TEFC heavy duty motor with thermal overload protection.
- 5 GPM positive displacement gear pump with internal relief valve.
- One (1) polyurethane powder baked F-1000 element housing.
- Wired 110 Volt, 1 phase with all electrical components mounted in a NEMA 4 enclosure.
- Starter switch with automatic/manual override circuit.
- Automatic high/low pressure shutdown system for unattended operation.
- 0-100 PSI glycerin filled gauge for monitoring system pressure.
- Plumbed with all brass fittings and 1/2" industrial hydraulic hose.
- 1/2" Inlet and outlet ball valves provided to isolate unit for element change.
- Two (2) 15 ft.-1/2" inlet and outlet hydraulic hoses with hose ends.
- Fifteen (15) feet of heavy duty 12/3 power cable.
- Manufactured with 3-way ball valve for fluid transfer system and to allow for adding makeup oil.
- Suction-Wye strainer to protect pump from large debris.
- Heavy duty 10" pneumatic tires.
- Filtration capacity of 3 GPM and fluid transfer capacity of 5 GPM.

Distributed by:

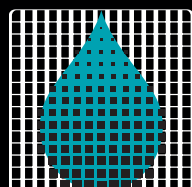

The
Fluid Life
Corporation



MODEL FP1105P

Water and Particulate Filtration System

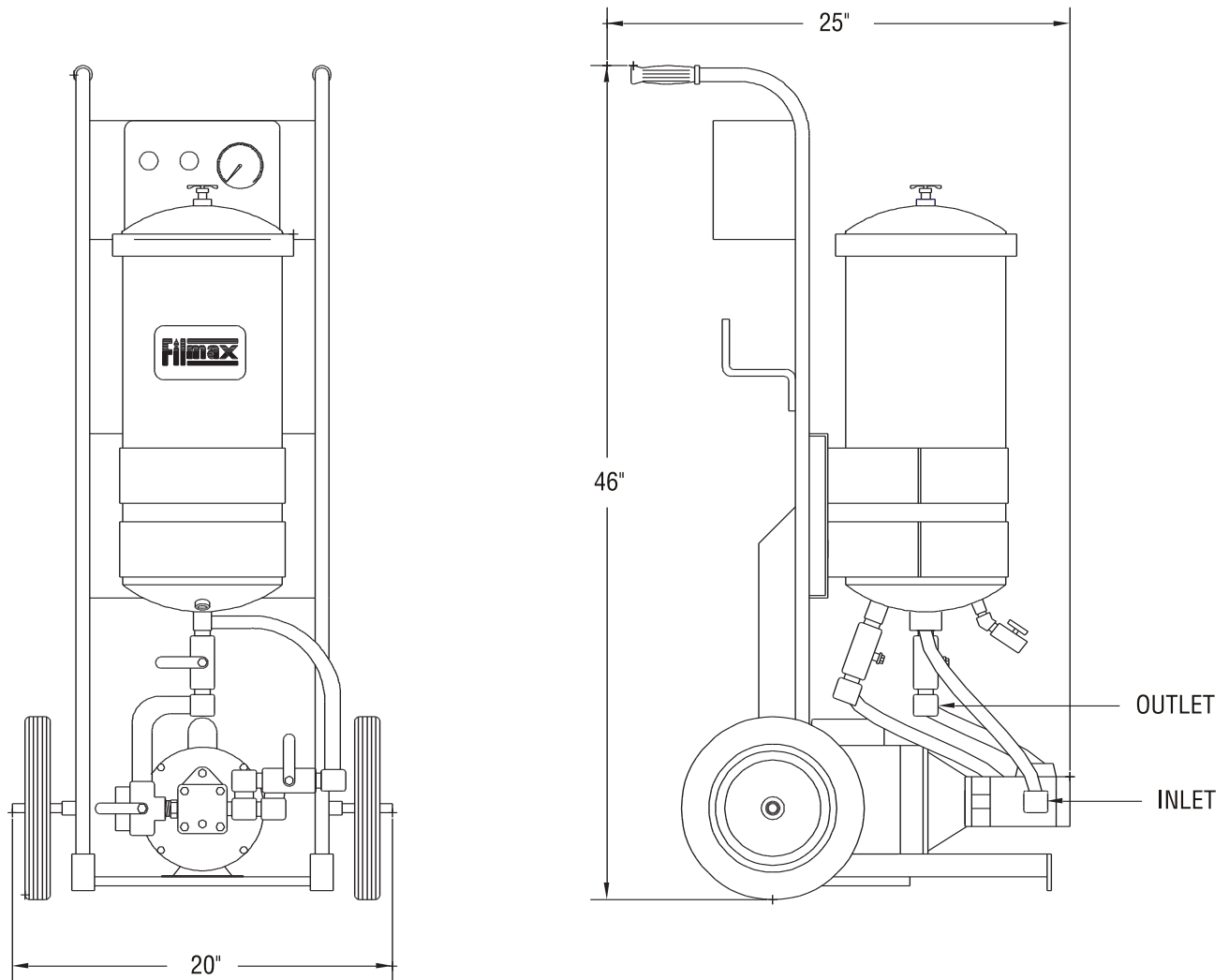

Filmax is the industry leader in the application of filtration technology for the removal of water and particulate contamination in insulating oil. Filmax holds the most recent patents for specific advancements in oil filtration technology, which allows the company to manufacture the finest oil filtration equipment in the industry. We at Filmax are committed and dedicated to providing the highest standard of customer service and technical support in the industry.

Head Office & Edmonton Laboratory:

The Fluid Life Corporation • 9321 - 48 St. • Edmonton, Alberta T6B 2R4 • Ph 780-462-2400 • Fax 780-462-2420 • Toll Free 1-877-962-2400

Ontario Laboratory:

The Fluid Life Corporation • 95 Copernicus Blvd. • Brantford, Ontario N3P 1N4 • Ph 519-720-9700 • Fax 519-720-9705