

Filmax

MODEL FP2130P PORTABLE FILTRATION SYSTEM

HIGH FLOW WATER & PARTICULATE FILTRATION SYSTEM FOR INDUSTRIAL AND SUBSTRATION MAINTENANCE



APPLICATIONS

Insulating Oil • Hydraulic Oil
Turbine Oil • Synthetic Oil

SPECIFICATIONS

- Heavy duty 2 HP TEFC 230 volt single phase Baldor motor with manual thermal overload protection.
- 30 GPM positive displacement mechanical seal gear pump with internal relief valve.
- One (1) polyurethane powder baked high flow F-3000 element housing.
- Wired 230 Volt 1 phase with all electric components mounted in a NEMA 4 enclosure.
- Automatic high/low pressure shutdown system for unattended operation.
- Starter switch with automatic/manual override circuit.
- Plumbed with all brass and black iron fittings and 100R1 high pressure hydraulic hose.
- 1½" inlet and outlet ports with cam loc fittings.
- Thirty (30) feet of heavy duty 12/3 power cord.
- Manufactured with 3-way ball valve for fluid transfer System.
- Suction-ye strainer to protect pump from large debris.
- 0-100 PSI glycerin filled gauge for monitoring system Pressure.
- Inline brass re-settable flow totalizer.
- Heavy duty 12" pneumatic tires.
- Filtration capacity of 27 GPM and fluid transfer capacity of 30 GPM.

Distributed by:

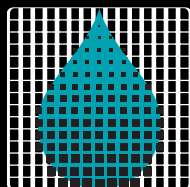

The
Fluid Life
Corporation



MODEL FP2130P

Water and Particulate Filtration System

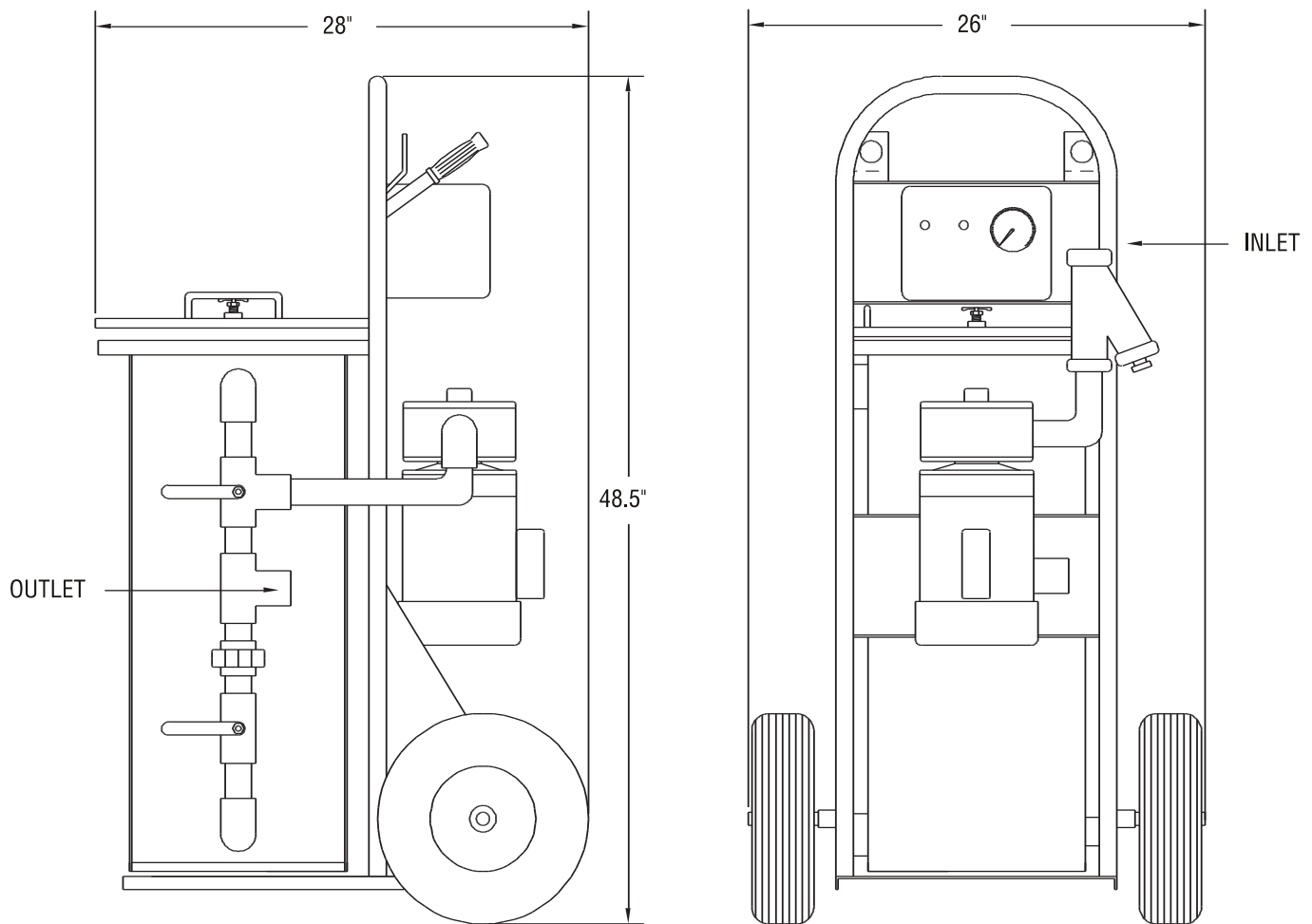

Filmax is the industry leader in the application of filtration technology for the removal of water and particulate contamination in insulating oil. Filmax holds the most recent patents for specific advancements in oil filtration technology, which allows the company to manufacture the finest oil filtration equipment in the industry. We at Filmax are committed and dedicated to providing the highest standard of customer service and technical support in the industry.

Head Office & Edmonton Laboratory:

The Fluid Life Corporation • 9321 - 48 St. • Edmonton, Alberta T6B 2R4 • Ph 780-462-2400 • Fax 780-462-2420 • Toll Free 1-877-962-2400

Ontario Laboratory:

The Fluid Life Corporation • 95 Copernicus Blvd. • Brantford, Ontario N3P 1N4 • Ph 519-720-9700 • Fax 519-720-9705