

Product Data Sheet

Product Name: STORAGE LID

Dimensions: Diameter - 147mm / 5.80 inches
Height - 105mm / 4.20 inches

Weight: 240 grams / 8.4 ounces

Material: High Density Polyethylene (HDPE)
Very chemically - resistant plastic however, contact with strong oxidising acids (eg. Ozone, Hydrogen Peroxide, Halogen etc) should be avoided.

NOT SUITABLE FOR USE WITH FUELS OR SOLVENTS

Service Temperature: - 40 Deg C to 80 Deg C / - 40 Deg F to 176 Deg F

Additives: UV Stabiliser
Anti Static Additive

Sealing Components: Nitrile O Ring (Buna N)

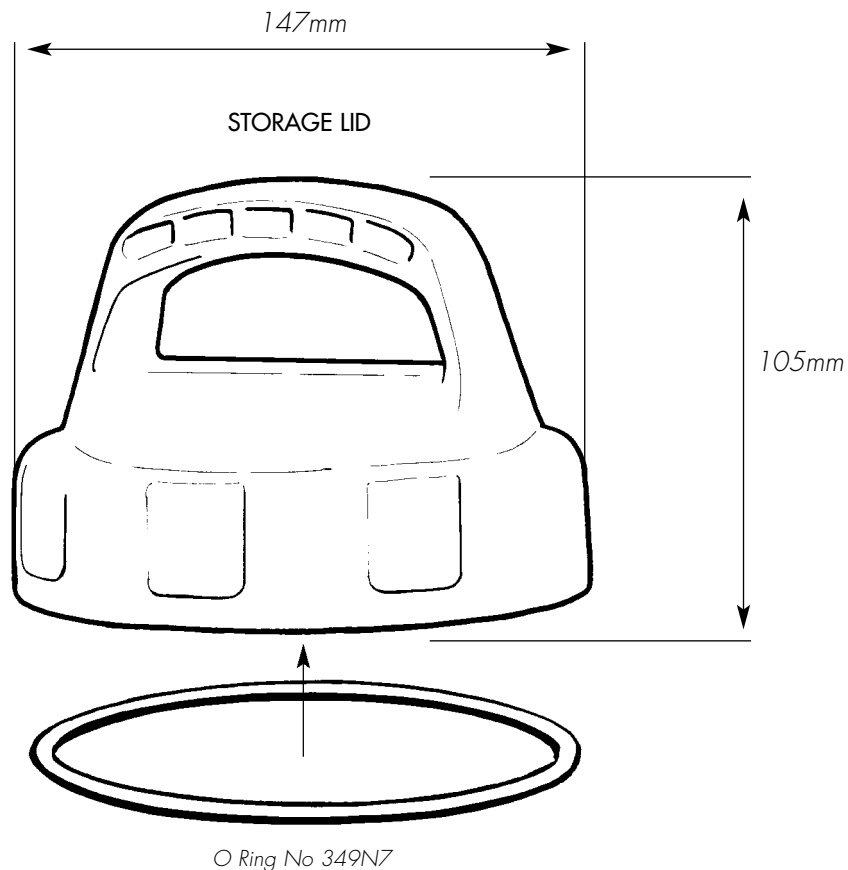

Distributed by:

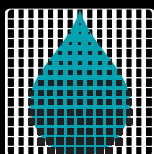

The
Fluid Life
Corporation

The Fluid Life Corporation

9321 - 48 St.
Edmonton, Alberta T6B 2R4
Ph 780-462-2400
Fax 780-462-2420
Toll Free 1-877-962-2400

95 Copernicus Blvd
Brantford, Ontario N3P 1N4
Ph 519-720-9700
Fax 519-720-9705
www.fluidlife.com