

WATER & PARTICULATE ULTRA FINE FILTRATION SYSTEM FOR INDUSTRIAL FLUID APPLICATIONS

Filmax Ultra Fine Filtration Maintains Fluids Within Aerospace Specifications Eliminating Sludge And Varnish In Fluid Power Systems

APPLICATIONS

Hydraulic Oils • Compressor Oils • Gear Oil
Synthetic Lubricants • Phosphate Ester Fluids
Insulating Oils • Turbine Oil • Water Glycols

SPECIFICATIONS

- 1/4 HP TEFC heavy-duty motor with thermal overload protection.
- 1 GPM mechanically sealed positive displacement gear pump with internal relief valve.
- One (1) polyurethane powder baked F-500 filtration element housing.
- Wired 110 VAC, 1 phase with manual starter switch.
- 0-100 PSI glycerin filled gauge for monitoring system pressure.
- Plumbed with all brass fittings and 1/2" industrial hydraulic hose.
- PSV – Pressure Setting Valve to adjust and control system pressure.
- 1/2" Inlet and outlet ball valves provided to isolate unit for element change.
- Two (2) 10 ft – 1/2" inlet and outlet hydraulic hoses with hose ends.
- Fifteen (15) feet of heavy duty 14/3 power cable.
- Suction-Wye strainer to protect pump from large debris.
- Filtration capacity of .5 GPM up to 30 GPH.
- Light-weight portable hand held design for those hard-to-service fluid reservoirs.

OTHER MODELS AVAILABLE:

FHH-503	F-500	135 GPH/2.25 GPM
FHH-703	F-750	150 GPH/2.50 GPM
FHH-1005	F-1000	180 GPH/3.00 GPM

*VISCOSITY

ISO32 AT 100° F



Distributed by:

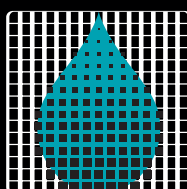

The
Fluid Life
Corporation

MODEL FHH-501



MAXIMUM ULTRA FINE FILTRATION FOR FLUID POWER SYSTEMS

PORTABLE HAND HELD WATER AND PARTICULATE FILTRATION SYSTEM

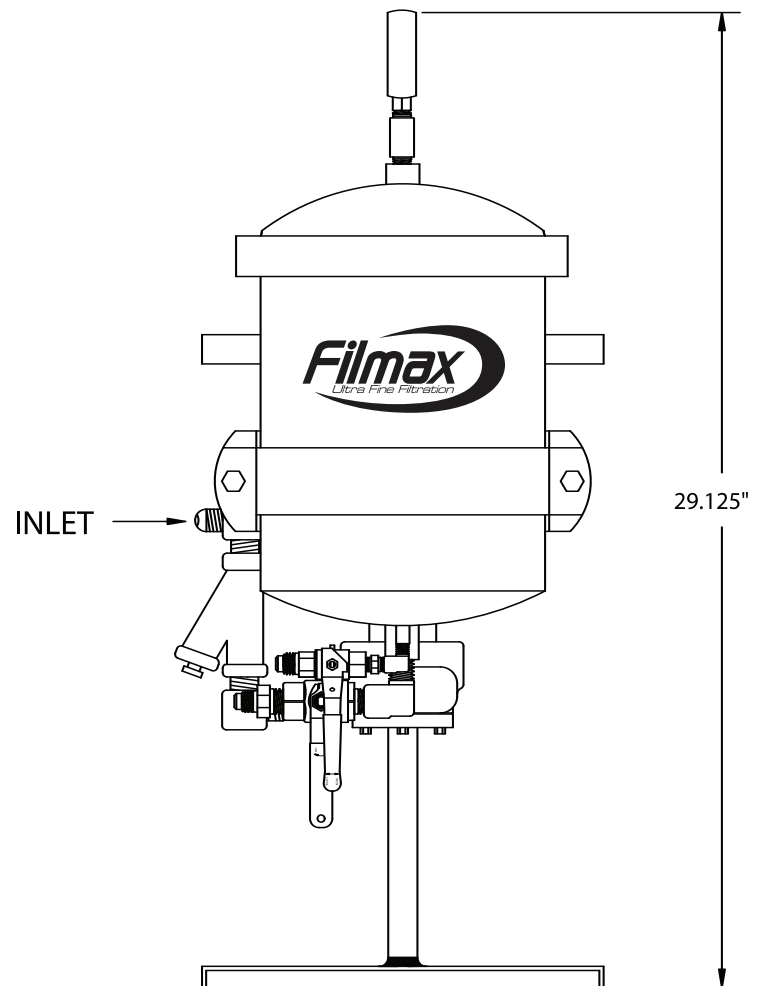
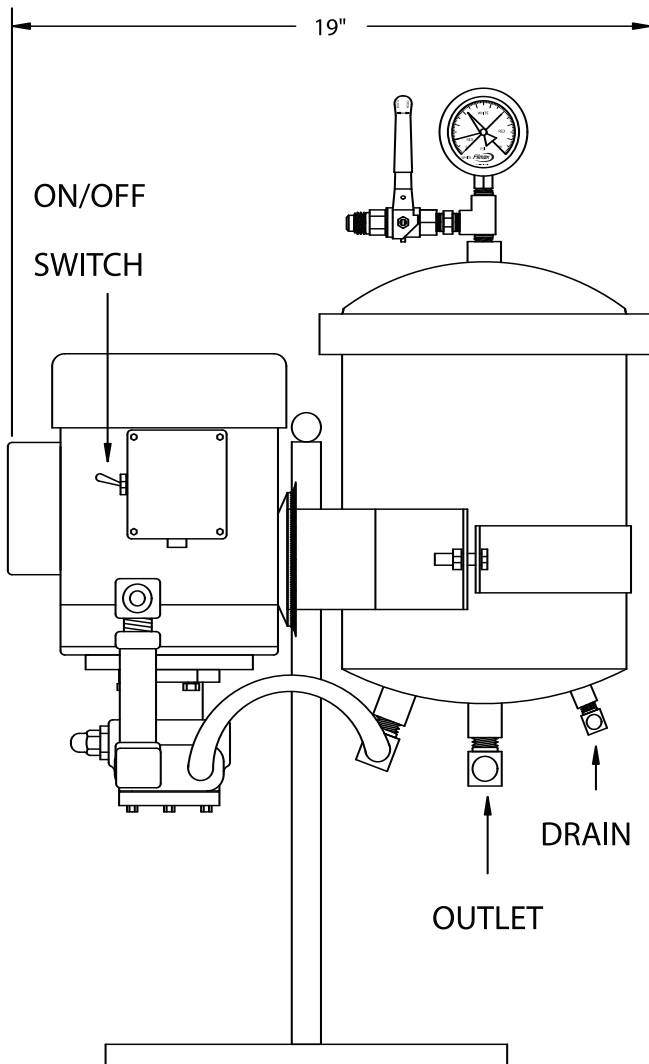

UNIT WEIGHT: 60lbs.
29.25" x 13" x 19"